

LBW311

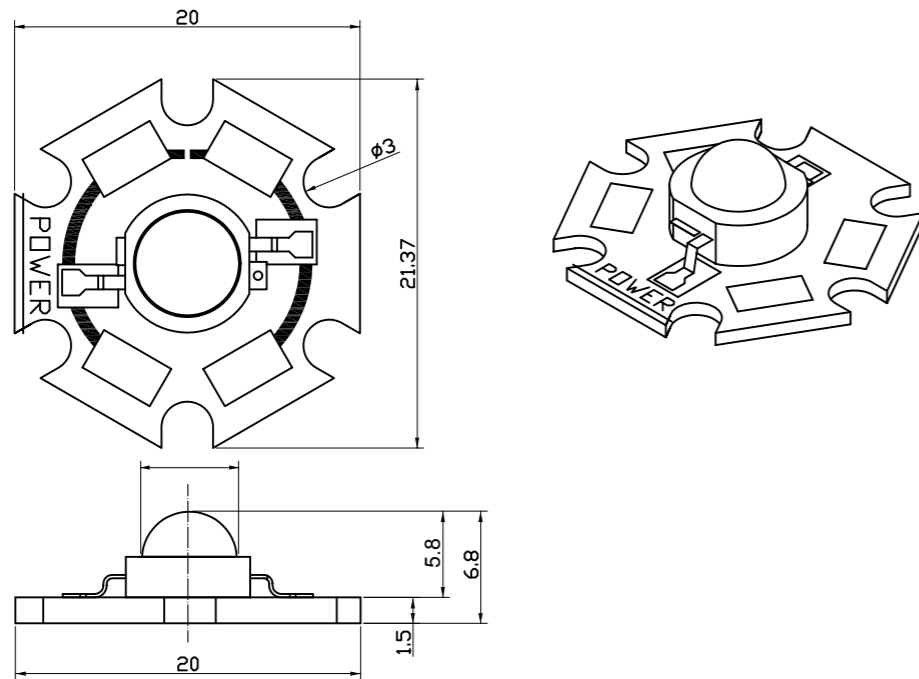

Features

- 1.Ultra - Luminance Using InGaN
- 2.High Forward Current Operation:350mA
- 3.High Thermal Conductivity

Application

- 1.Backlight
- 2.Indicator
- 3.Lighting

Part No.	Color	Wavelength	Power	Continuos Forward Current	Forward Voltage	Operating Temperature Range	Half Viewing Angle
		d	Watt	mA	If=180mA		2 1/2
KTW301R	Red	625nm	1w	350mA	1.8v-2.4v	-20°C to +80°C	60deg
KTW301Y	Amber	590nm	1w				
KTW301B	Blue	470nm	1w		2.8v-3.8v		
KTW301PG	Pure green	525nm	1w				
KTW301W	White	3000K-5000K	1w				
KTW301WW	Warm White	2500K-3500K	1w				

Forward Current Characteristics, T_j=25°C

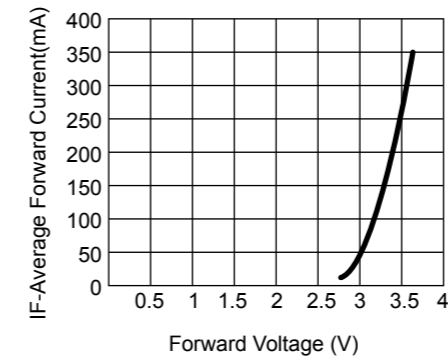

Forward Voltage (V)
Forward Voltage for White, Blue and Green.

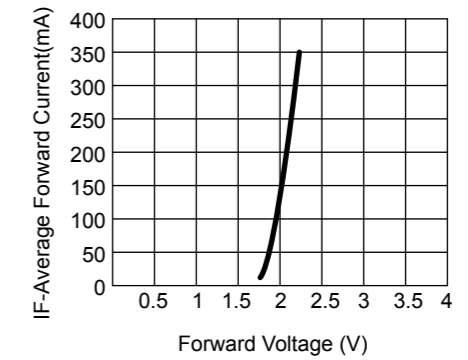

Forward Voltage (V)
Forward Voltage for Yellow and Red.

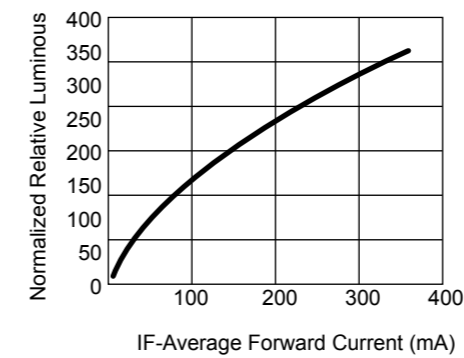

Relative Luminous Flux vs.
Forward Current for White, Blue and Green at T_j=25°C maintained.

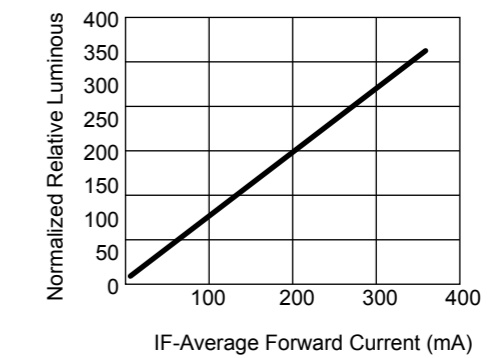

Relative Luminous Flux vs.
Forward Current for Yellow and Red at T_j=25°C maintained.

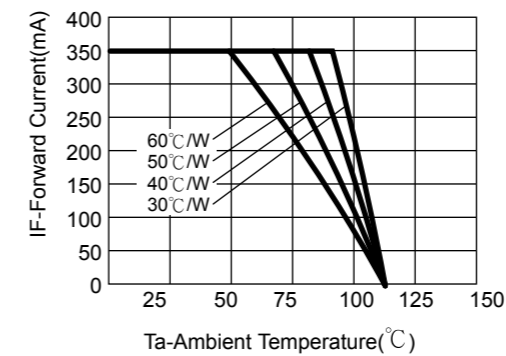

Maximum Forward Current vs.
Ambient Temperature. Derating based on T_jMAX=135 for White, Blue and Green.

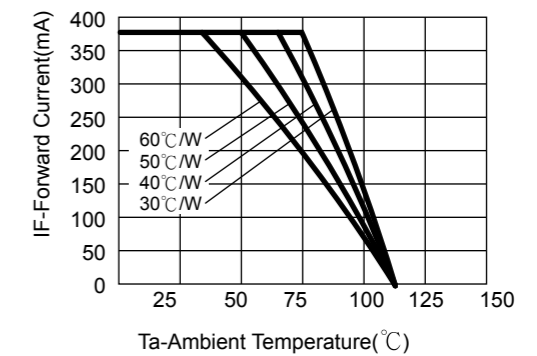

Maximum Forward Current vs.
Ambient Temperature. Derating based on T_jMAX=120 for Yellow and Red.